

オプション —トルクアーム—

FSタイプ(中空軸)・トルクアーム(オプション)

図1



図2



品番	該当枠番	図	A	B	C	D	E	F	G	H	J	K ₁	K ₂	L ₁	L ₂	M ₁	M ₂	M ₃	Y	T	質量 (kg)
TA-25	25	1	63	47	47	31	61	16	—	—	19	44	—	φ11	φ6.5	R15	R10.5	R 7	R34	4.5	0.3
TA-30	30	1	70	52	53	35	70	17	—	—	20	50	—	φ11	φ9	R15	R12	R 9	R39	6	0.5
TA-35	35	2	82	62	64	44	94	18	126	146	26	56	88	φ13	φ9	R18	R12	R10	R43.5	6	1.2
TA-45	45	2	102	72	80	50	110	22	152	182	32	70	104	φ15	φ11	R20	R15	R11	R51	9	3.0
TA-55	55	2	129	93	97	61	160	32	190	226	39	90	132	φ18	φ13	R25	R20	R13	R70	9	4.8

材質	表面処理	色
SS400	三価クロメート	白

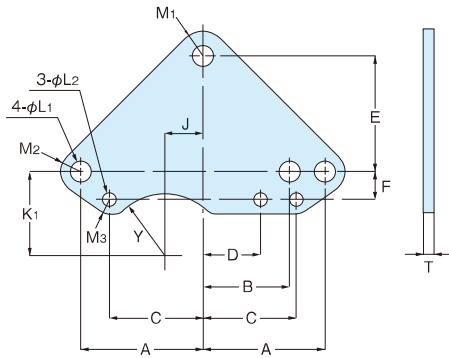
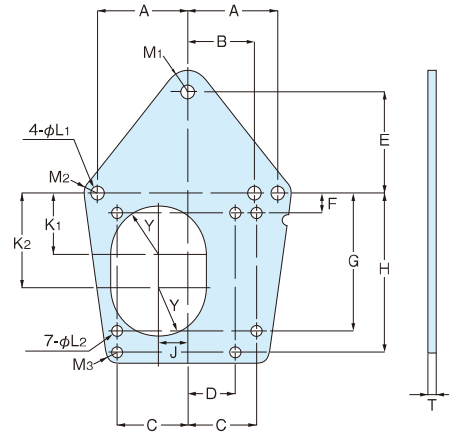
F3Sタイプ(中空軸)・トルクアーム(オプション)

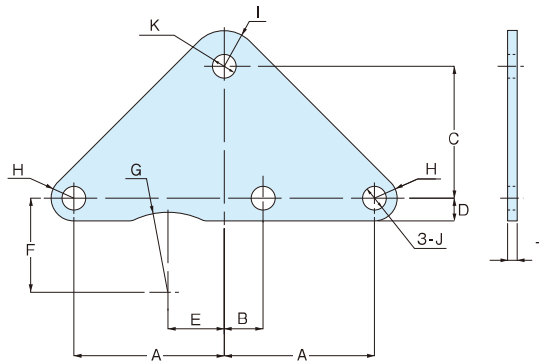

仕様

該当枠番	品名	容量	該当減速比	A	B	C	D	E	F	G	H	I	J	K	T	質量 (kg)
20	TAF3S-20-2	0.2 kW	1 / 5~1 / 30	53.5	23.5	52	10.5	—	—	—	R10.5	R11	φ11	φ 9	3.2	0.1
		0.1 kW	1 / 5~1 / 60													
25	TAF3S-25-2	0.4 kW	1 / 5~1 / 30	60	27	61	10.5	16.5	43.5	R37	R10.5	R15	φ11	φ 9	3.2	0.2
		0.2 kW	1 / 5~1 / 60													
30	TAF3S-30-2	0.75 kW	1 / 5~1 / 30	69.5	26.5	70	10.5	21.5	48	R41.5	R10.5	R15	φ11	φ11	4.5	0.3
		0.4 kW	1 / 5~1 / 60													
		0.2 kW	1 / 80~1 / 240													
35	TAF3S-35-2	1.5 kW	1 / 5~1 / 30	80.5	31.5	94	12	24.5	56	R46.5	R12	R18	φ13.5	φ13.5	6	0.6
		0.75 kW	1 / 5~1 / 60													
		0.4 kW	1 / 80~1 / 240													
45	TAF3S-45-2	1.5 kW	1 / 5~1 / 60	103.5	42.5	110	15	—	—	—	R15	R20	φ17.5	φ17.5	9	1.4
		2.2 kW	1 / 5~1 / 30													
		0.75 kW	1 / 80~1 / 240													
50	TAF3S-50-2	2.2 kW	1 / 40~1 / 60	136	44	140	15	—	—	—	R15	R20	φ17.5	φ17.5	9	2.1
		0.1 kW														
55	TAF3S-55-3	1.5 kW	1 / 80~1 / 240	146	70	160	18.5	—	—	—	R18.5	R28.5	φ20.5	φ20.5	12	3.6
		2.2 kW	1 / 80~1 / 120													
		0.1 kW														

材質	表面処理	色
SS400	三価クロメート	白